



### Specifications: CM1001d

### Tile bridge included

System Type	10" Subwoofer, in-ceiling, ported (150 Watt optional transformer for 25/70.7/100 Volt or 4 ohm direct)
Impedance (nominal) <sup>1</sup>	4 ohm
Sensitivity dB @ 2.83V/1M	96.5dB
Sensitivity dB @ 1W/1M <sup>2</sup>	93.5dB
Distance Factor	N/A
Frequency Response (-3 dB) <sup>3</sup>	53 Hz - 120 kHz
Frequency Response (-10 dB) <sup>3</sup>	40 Hz - 300 kHz
Max. Program Power <sup>4</sup>	300w
Max. Continuous Power RMS <sup>5</sup>	150w
Max. UL program power	100w
Max. Power SPL @ 1 M <sup>6</sup>	115.5dB
Max. SPL @ x% distortion <sup>7</sup>	N/A
Coverage Angle (-6 dB @ 2 kHz)	N/A
Coverage Angle (-6 dB @ 10 kHz)	N/A
Directivity Factor (Q)	N/A
Directivity Index (DI) dB	N/A
Tap Selector	5-Position rotary switch with 4 ohm direct
Transducer - Low Frequency Driver	254mm (10in) Polypropylene cone, butyl rubber surround
Transducer - High Frequency Driver	N/A
Low Frequency Voice Coil	35.0mm 1.38in
Crossover Frequency	100.0 kHz
Network Type: Low Pass	6dB per octave, 1st order
Network Type: High Pass	N/A
Enclosure Material	Drawn steel backcan with ABS baffle
Motor-board	N/A
Grille	Iridite-plated steel with powder-coat finish
Inputs	4 Pin, 5mm Euroblock for individual or daisy chain connection
Colors	Black or white
Backcan Diameter	11.68 in / 296.7 mm
Backcan Height	11.77 in / 299.0 mm
Visible Diameter	14.76 in / 374.9 mm
Visible Height	1.08 in / 27.4 mm
Mounting Hole Diameter	12.75 in / 323.9 mm
Min / Max Ceiling Thickness	0.25 in / 6.4 mm – 1.69 in / 42.9 mm
Weight	27.0 lb / 12.3 kg
Shipping Weight	32.0 lb / 14.5 kg
<b>Accessories</b>	
Included	Tile bridge, Euroblock connector & installation aid
Optional	Pre-Construction Bracket (AC-CM8-PCB), Junction Box (AC-CM-JBOX)
Packaging	1 per box

### Transformer Taps

70.7 V Output	100 V Output	25 V Output
150w 115.5dB	150w 115.5dB	19w 106.5dB
75w 112.5dB	75w 112.5dB	9.5w 103.5dB
38w 109.5dB	38w 109.5dB	4.8w 100.5dB
19w 106.5dB		2.4w 97.5dB

<sup>1</sup> Impedance listed per IEC 60268-5 with a minimum less than 80% the nominal impedance

<sup>2</sup> 1w1m sensitivity determined using nominal impedance

<sup>3</sup> Frequency response measured in half or full space as dictated by speaker mounting configuration

<sup>4</sup> Max program power is 3 dB above max continuous power

<sup>5</sup> Continuous power rating, EIA-426-B test

<sup>6</sup> Max output based on max continuous power

<sup>7</sup> Max useable SPL based on testing by NWA Labs

### Key Features

- One 254 mm (10.0 in) polypropylene woofer.
- 150 Watt optional transformer and high output (115.5 dB) for the sound reinforcement and PA markets.
- Rapid installation blind-mount, fixed-wing mounting mechanism mounting mechanism with constant tension design affixes to ceiling thicknesses ranging from 6.4 mm (0.25 in) to 42.9 mm (1.69 in).
- Separate tool-free magnetic grille & bezel assembly for ease of install & in-field painting.
- Iridite-plated steel grille with protective powder-coated finish for lasting durability.
- Easy access 5-position selectable tap switch for 25, 70.7, 100 Volt and low impedance applications simplifies ordering & inventory tracking.
- 93.5 dB sensitivity (1w/1m) offers high-output capabilities & reduced amplification costs.
- UL 2043 & 1480 approval pending.
- Included accessories: Tile bridge, Euroblock connector & paint mask.
- Optional accessories: Pre-construction bracket, junction box.

### Description

The CM1001d is an 10" in-ceiling subwoofer design that delivers additional low-end response (40 Hz) for satellite/subwoofer applications. The CM1001d speaker design incorporates a low-profile grille and 5-position tap switch with 4 Ohm direct. All mounting hardware is included and features a fast and secure fixed-wing mounting system.

### Applications

Designed for in-ceiling background subwoofer applications, the CM1001d includes a proprietary fixed-wing constant-tension mounting system for ease of installation. True low-end response (40 Hz) and high sensitivity (93.5 dB 1W/1M) make the CM1001d ideal for additional bass response in convention centers, airports and other large venue in-ceiling subwoofer applications.

### Patented SoundTube Technologies

SoundTube Entertainment is constantly developing new technologies that enhance audio product performance. SoundTube

**Frequency Response**

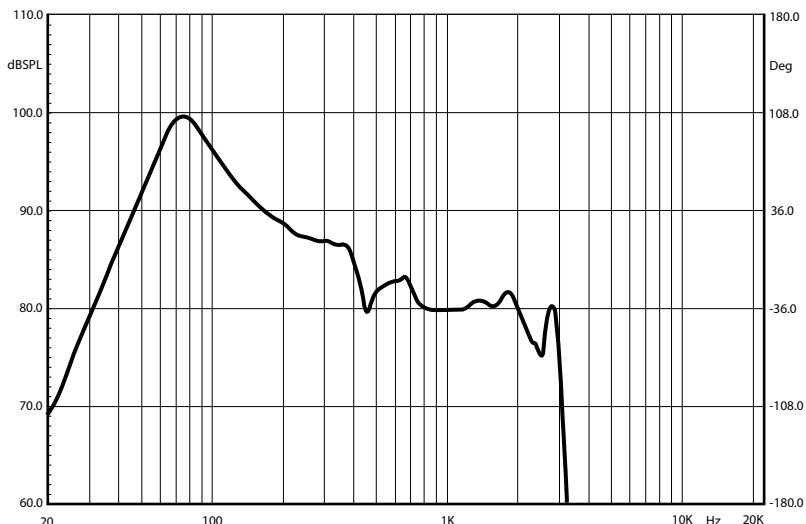

**Phase/Impedance Reponse**

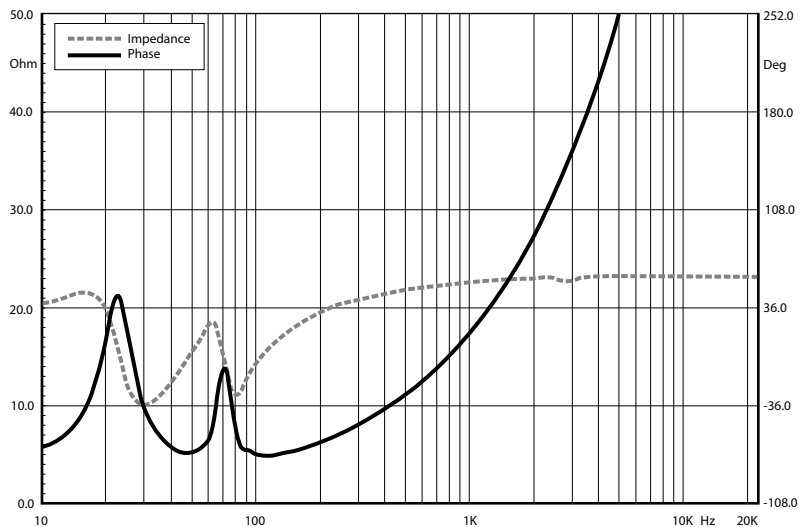

Entertainment innovations are protected by multiple U.S. & international patents, which explicitly cover SoundTube dome, enclosure and dispersion technologies. SoundTube Entertainment actively defends its patents in order to protect SoundTube resellers and end users.

**Technical Data and Specification Tools**

**Technical Data**

SoundTube Entertainment strives to provide complete and effective technical information and data to dealers, engineers and designers. All data are available from SoundTube Entertainment or at [www.soundtube.com](http://www.soundtube.com).

**Data Acquisition**

All performance data acquired at SoundTube's Technical Measurement Center (TMC) are analyzed using a variety of standard measurement techniques, including Measured Length Sequence (MLS) and Time Delay Spectrometry (TDS). Performance, development and data acquisition tools include: Gold Line TEF 20, CLIO, LMS, LEAP, and proprietary modeling software. EASE™ data are acquired through an automated CLIO/Outline/EASE™ interface.

**EASE™ Data** – 3-D polar plots.

**SoundTubeSPEC™** – Proprietary SoundTube speaker placement software.

**Architectural Specifications**

The loudspeaker shall consist of a 254 mm (10.0 in) low-frequency transducer with a frequency-dividing network installed in the vented enclosure. The low-frequency voice coil diameter shall be 35.0 mm (1.38 in).

Performance specifications of a typical production unit shall be as follows: Useable frequency response shall extend from 40 Hz – 300 Hz (-10 dB, half space, no external equalization). Measured sensitivity (1 watt, 1 meter) shall be at least 93.5 dB. The speaker shall have a nominal impedance of 4 Ohms and be available for 25, 70.7 & 100 Volt modes with voice coil/4 Ohm direct. The frequency-dividing network shall have a crossover frequency of 100 Hz with a 6 dB per octave (1st order) slope for the low pass filter. Rated power capacity shall be at least 150 Watts continuous power (RMS) and conform to EIA-426-B testing. Maximum continuous output at 1 meter shall be 115.5 dB.

Installation for the CM1001d shall be by 2-screw blind-mount, constant-tension winged assembly and shall attach to ceiling thickness tolerances ranging from 6.4 mm (0.25 in) to 42.9 mm (1.69 in). The fixed-wing assembly shall be constructed of iridite-plated, powder coated steel. The external

# CM1001d

## In-Ceiling Speaker

Technical Information for System Engineers



**SOUNDTUBE**  
ENTERTAINMENT

### Included Accessories

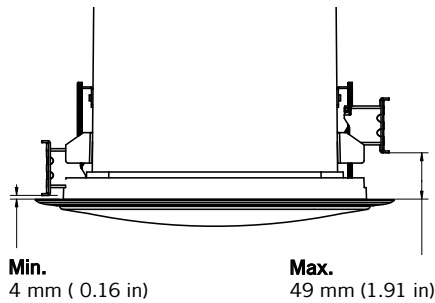

Min.  
4 mm ( 0.16 in)

Max.  
49 mm (1.91 in)

### Fixed Wing Mounting System

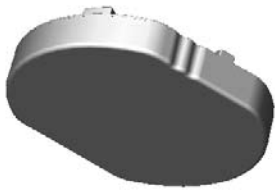

Paint Mask

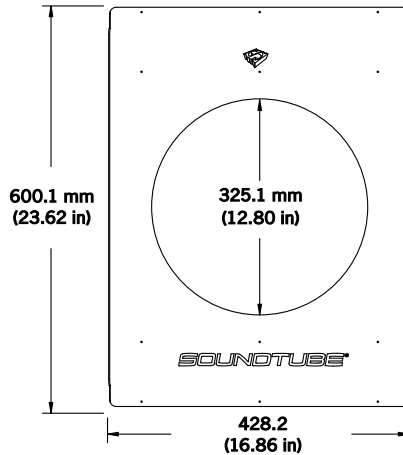

Tile Bridge

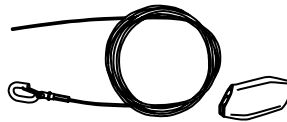

Suspension Cable & Hardware

### Optional Accessories

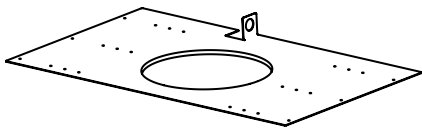

Pre-Construction Bracket (AC-CM8-PCB)

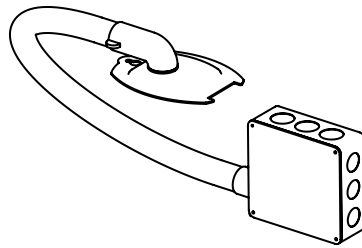

Junction Box (AC-CM-JBOX)

wiring input connector shall be a 4-pin, 5 mm Euroblock for 4 Ohm or distributed systems and shall accept from 10 – 22 gauge wire.

The maximum backcan dimensions shall be no more than 299 mm (11.77 in) in height by 296.7 mm (11.68 in) in diameter. The maximum visible dimensions shall be no more than 274 mm (1.08 in) in height by 374.9 mm (14.76 in) in diameter. The backcan shall be constructed of iridite-plated steel.

The system shall include a 16-gauge galvanized steel support backing plate (tile bridge) to reinforce the ceiling material and tile support rails. The maximum tile bridge dimensions shall be no more than 600.1 mm (23.62 in) in length by 428.2 mm (16.86 in) in width and 10.4 mm (0.41 in) in thickness with 325.1 mm (12.80 in) cutout for speaker mounting.

The grille shall be constructed of iridite-plated, powder-coated steel with an ABS bezel for lasting performance. The affixed grille and bezel shall be mounted to the speaker enclosure (backcan) via magnetic strip. Also included are a paint mask for in-field painting and an installation aid that serves as a handhold during mounting.

The CM1001d has an optional Pre-Construction Bracket (AC-CM8-PCB) that shall be compatible with an optional Junction Box (AC-CM-JBOX). An 18-gauge wire whip and Euroblock connector shall be included with the junction box. The maximum dimensions of the Pre-Construction Bracket shall be no more than 635 mm (25.0 in) in length by 457.2 mm (18.0 in) in width and 127 mm (5.0 in) in thickness with a 326.5 mm (12.85 in) cutout for speaker mounting.

The system shall be the SoundTube CM1001d subwoofer for both low & high impedance applications.

### SoundTube Entertainment

6430 North Business Park Loop  
Park City, Utah 84098  
Phone 435.647.9555  
Fax 435.647.9666  
Toll Free 800.647.TUBE  
www.soundtube.com

**All SoundTube products come with a 5-year limited warranty.**

