

FP6030-II | Sound-Focusing Speaker

Preliminary Technical Information for System Engineers



Preliminary Specifications: FP6030-II

System Type	2 x 25 mm stereo or mono high directivity (8 ohm stereo, 4 ohm mono). Optional transformer for distributed systems (25/70.7/100-volt).
Impedance (nominal) ¹	8 ohm stereo, 4 ohm mono
Sensitivity dB @ 2.83 V/1 m	75.0 dB
Sensitivity dB @ 1 W/1 m ²	75.0 dB
Frequency Response (-3 dB) ³	160 Hz - 22 kHz (300 Hz with high pass filter)
Frequency Response (-10 dB) ³	130 Hz - 22 kHz (300 Hz with high pass filter)
Max. Program Power ⁴	30 W
Max. Continuous Power RMS ⁵	15 W
Max. Power SPL @ 1 m ⁶	87.0 dB
Coverage Angle (-6 dB @ 2 kHz)	65°
Coverage Angle (-6 dB @ 10 kHz)	55°
Coverage Angle (averaged from 2 to 10 kHz)	45°
Directivity Factor (Q)	23.4 (averaged 100 Hz - 10 kHz); 27.5 (2 kHz)
Directivity Index (DI)	12.4 dB (averaged 100 Hz - 10kHz); 14.4 dB (2 kHz)
Tap Selector	Optional j-box transformer with four-position rotary switch
Transducers	Twin 25mm (1.0 in) full range aluminum convex
Low-Frequency Voice Coil	20.5 mm (0.81 in)
High-Pass Filter	150 Hz or 300 Hz switchable
Network Type: High Pass	6 dB per octave, 1st order
Dome Material	Clear PETG dome
Grille and Enclosure material	High impact polystyrene
Inputs	Four-conductor 16-gauge hardwire leads, CAT-V cable included for optional accessories
Colors	Clear dome, black pod, optional black or white domes available
Height	332.7 mm (13.10 in)
Dome Diameter	781.1 mm (30.75 in)
Weight	4.1 kg (9.0 lbs.)
Shipping Weight	9.3 kg (20.5 lbs.)
Packaging	1 per box, bulk packaging available
Accessories Included	Hanging hardware, mounting bushing and 15-foot hardwire lead
Accessories Optional	Motion sensor (FP-Motion), LED light (FP-Light), FP-ScentAir™ and amplifier (FP-Amp). Additional accessories include 15-volt, 5-amp power supply (AC-PS-1550) 10- or 20-watt transformers with junction box for 25-, 70.7- and 100-volt applications (AC-JB10-XFMR, ACJB20-XFMR), amplification unit with power supply (SA201-RDT or SA202-RDT), wall bracket (WB4) and rigid mount adaptors (FP-AC-RMA).
Regulatory - CE	Approved
	Transformer Taps

¹ Impedance listed per IEC 60268-5 with a minimum less than 80% the nominal impedance

² 1 W 1 m sensitivity determined using nominal impedance

³ Frequency response measured in half or full space as dictated by speaker mounting configuration

⁴ Max program power is 3 dB above max continuous power

⁵ Continuous power rating, EIA-426-B test

⁶ Max output based on max continuous power

70.7 V Output		100 V Output		25 V Output	
10 W	85.0 dB	10 W	85.0 dB	1.25 W	76.0 dB
5 W	82.0 dB	5 W	82.0 dB	.63 W	73.0 dB
2.5 W	79.0 dB	2.5 W	79.0 dB	.32 W	70.0 dB
1.25 W	76.0 dB			.16 W	67.0 dB

Key Features

- Patented Dual-Parabolic™ dispersion control technology provides a targeted audio footprint with true stereo separation.
- Patented ZeroReflection™ enclosure technology for accurate sound reproduction.
- Narrow 45° coverage angle for sharp focus (average 2 - 10 kHz, independently verified).
- 781.1 mm (30.75 in) Custom-molded PETG clear polymer dome for minimal visual impact.
- Twin 25 mm (1.00 in) concave aluminum high-excursion drivers in individually sealed compartments for stereo or mono music and messaging.
- User-selectable 300 Hz high-pass filter.
- Single-point balanced mounting for easier and clean looking installs.
- Included accessories: hanging cable, hanging bracket, mounting bushing and a 15-foot cable which includes four 16-gauge inputs and a CAT V cable.
- Optional modules include motion sensor (FP-Motion), LED light (FP-Light) and Amplification (FP-Amp), scent unit (FP-ScentAir™), optional 15-volt, 5-amp power supply necessary for all module accessories (AC-PS-1550). The FP6030-II-ScentAir ships plumbed for scent unit (scent unit sold separately, visit www.scentair.com for details).
- Optional electronic accessories include 10- and 20-watt transformers with junction box for 25-, 70.7- and 100-volt applications (AC-JB10-XFMR, ACJB20-XFMR) and an external amplification unit with power supply (SA201-RDT or SA202-RDT) for use with any FP module.
- Additional optional accessories include: wall bracket, sound sleeves and rigid mount adaptor.
- Ships with clear dome, custom colors available.
- Ships as individual unit, bulk shipping available.

Description

The FP6030-II delivers targeted audio in a unique package by incorporating two full-range, high-performance 1.0 in concave aluminum dome high-excursion drivers with patented 30.75 in diameter Dual-Parabolic™ sound dome technology.



Standard and ScentAir™ models can be wired in either 8 ohm stereo or 4 ohm mono with optional 25/70.7/100-volt transformer available.

FP-Specific Modular Options

SoundTube-engineered modular options enhance and expand FP series performance characteristics and applications. Modules include motion sensor (FP-Motion), LED light (FP-Light), amplifier (FP-Amp), and the FP-ScentAir™, which delivers scented marketing solutions in an audio package. A 15-volt, 5-amp power supply (AC-PS-1550) is necessary to drive all FP modules, combined or individually.

FP-Motion

The motion sensor (FP-Motion) functions as an instant-on with a time-delay off. The time-delay off is installer-adjustable and ranges from 1 to 12 seconds. The FP-Motion includes a stereo signal path relay to complete the audio circuit, delivering sound when motion is detected. To trigger external devices, the motion sensor includes a 12-volt output signal and contact closure.

FP-Light

The light option (FP-Light) delivers a natural warm LED light, which can be used in conjunction with the motion sensor and amp, but not the ScentAir™. Light intensity is governed either globally or locally via an onboard brightness control centered on the motherboard. To activate the light from motion, the FP-Motion module may be used.

FP-Amp

The 20-watt per channel digital stereo amp (FP-Amp) is highly functional and easy to use. The FP-Amp gain can be controlled either globally or locally. To maximize output and fidelity while minimizing distortion, the FP-Amp incorporates a factory-present digital equalizer and driver protection circuitry.

The FP-Amp signal is accepted from either a stereo input via four 16-gauge hardwire leads or a built in mini-SD card reader. As a default, the FP-Amp accepts input from the signal wires unless an SD card with a message is installed. The mini SD reader accepts .wav or .mp3 formats and will play the message continuously (unless used with motion sensor or external trigger).

FP6030-II-ScentAir™

The FP6030-II-ScentAir™ ships with the motion sensor and is pre-plumbed for use with a ScentAir™ (scent unit sold separately). It may be used in conjunction with the amplifier for maximum audio output and intelligibility. The ScentAir™ unit must be purchased through an authorized ScentAir™ reseller. Visit www.scentair.com for more information.

Additional accessories include 10- and 20-watt transformers with junction box for 25-, 70.7- and 100-volt applications (AC-JB10-XFMR, ACJB20-XFMR) and an external amplification unit with power supply (SA201-RDT or SA202-RDT).

Applications

High-definition music and messaging with tight coverage, full-range stereo sound (130 Hz – 22 kHz, - 10 dB) and true audio containment (45° averaged 2 – 10 kHz) make the FP6030-II the ideal choice for focused audio applications including kiosks, P.O.P. displays, trade shows, digital signage or anywhere contained high-fidelity stereo or mono sound is required but visual impact must be minimized.

Patented Dual-Parabolic™ Technology

By incorporating patented Dual-Parabolic™ dome technology, the FP series provides a targeted hot-spot with definitive stereo separation. With sound waves projected into the dome, SoundTube's proprietary technology reflects sound waves from the mid and upper registers of the frequency spectrum directly beneath the dome.

SoundTube Entertainment and the MSE Audio Group constantly develop new technologies, which enhance audio product performance. SoundTube Entertainment innovations are protected by multiple U.S. and international patents, which explicitly cover SoundTube dome, enclosure and dispersion technologies. The MSE Audio Group actively defends its patents in order to protect SoundTube resellers and end-users.

Technical Data and Specification Tools

Technical Data

SoundTube Entertainment strives to provide complete and effective technical information and data to dealers, engineers and designers. All data are available from SoundTube Entertainment, or at www.soundtube.com.

Technical data and downloads include:

EASE™ data – 3-D polar plots.

EASE™ Address – 2-D modeling for distributed systems

Autodesk® Revit® software

Tech Sheets – Technical information and architectural specs for system engineers

SoundTubeSPECT™ – Proprietary speaker placement software.

Independent Data Acquisition and Verification

All data for SoundTube speakers are independently collected and verified by NWAALabs (www.nwaalabs.com) using their proprietary MACH testing system. All data are collected and analyzed according to ASTM, ISO and AES standards using EASERA, TEF and MLSSA. Full balloon data including both phase and magnitude are compiled into a variety of formats including EASE 4.x, GLL and CLF.

Architectural Specifications

The loudspeaker shall consist of two 25 mm (1.0 in) transducers with a voice coil diameter of 20.5 mm (0.81 in). Sound waves from the transducers shall be reflected from a 781.1 mm (30.75 in) Dual-Parabolic™ sound dome.

Performance specifications of a typical unit shall be as follows: Useable frequency response shall extend from 130 Hz – 22 kHz (-10 dB). Measured sensitivity (2.83-volt input, 1 meter) shall be at least 75 dB stereo. The loudspeaker shall ship with a CAT V plus four 16-gauge hardwire leads and be available in 8 ohm impedance mode (4 ohm if bridged/mono), or with an optional 25/70.7/100-volt transformer and accompanying junction box. For the transformer accessory, the transformer unit and four-position tap switch will be supplied in a junction box.

Frequency Response

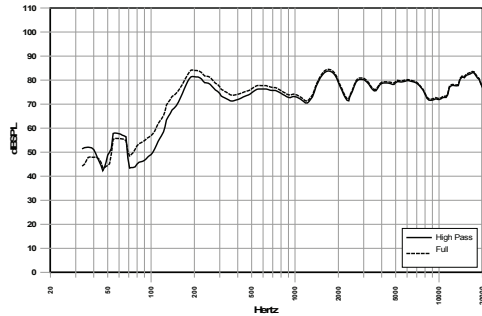

Impedance/Phase

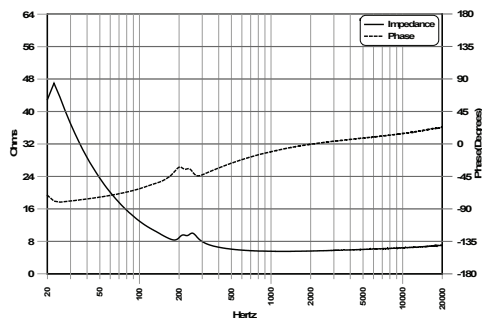

Vertical Beamwidth

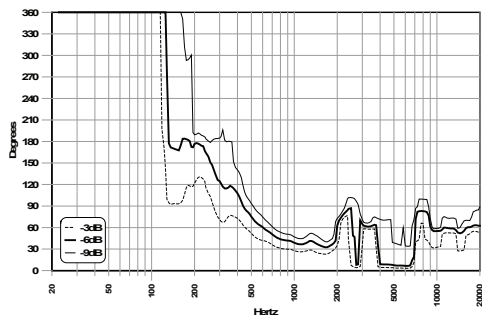

Directivity Index (DI)

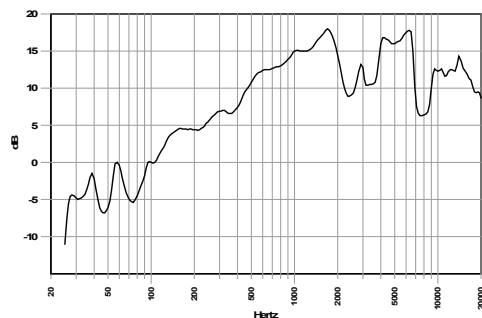

The dome shall be constructed of custom-molded PETG with a high-impact polystyrene driver enclosure. The transducers shall have a concave aluminum diaphragm with high-impact polystyrene transducer protectors. The overall unit dimensions shall be no more than 781.1 mm (30.75 in) in diameter by 332.7 mm (13.10 in) in height and weigh no more than 4.1 kg (9.00 lbs).

Installation for the FP6030-II shall be by single-point hanging with the cable affixed to a mounting bushing and hanging bracket.

Optional modules include motion sensor (FP-Motion), LED light (FP-Light) and Amplifier (FP-Amp) and an optional FP system includes FP6030-II ScentAir™ which ships plumbed to accept scented marketing solutions. All FP modules require one AC-PS-1550 power supply to power any combination of modules.

Optional electronics accessories include 10- and 20-watt transformers with junction box for 25, 70.7 and 100-volt applications (AC-JB10-XFMR, ACJB20-XFMR) and an external amplification unit with power supply (SA201-RDT or SA202-RDT). Also available are custom printed sound sleeves, wall bracket (WB4) and rigid mount adaptors (FP6-RMA).

The system shall be the FP6030-II or FP6030-II ScentAir™ for 8 ohm or distributed systems.

SoundTube Entertainment

6430 North Business Park Loop
 Park City, Utah 84098
 Phone 435.647.9555
 Fax 435.647.9666
 Toll Free 800.647.TUBE
 www.soundtube.com

All SoundTube products come with a 5-year limited warranty.

FP6030-II

High Power Speaker

Technical Information for System Engineers



SOUNDTUBE
ENTERTAINMENT

Polar Plots

— Horizontal
- - - Vertical

125 Hz

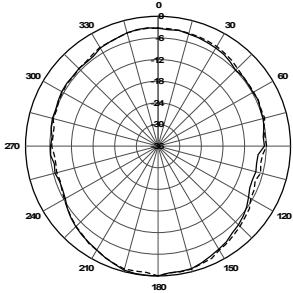

250 Hz

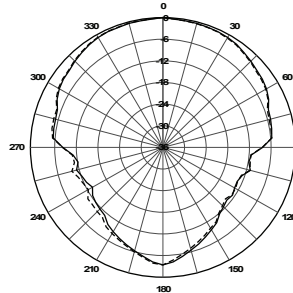

500 Hz

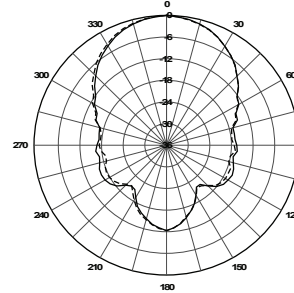

1,000 Hz

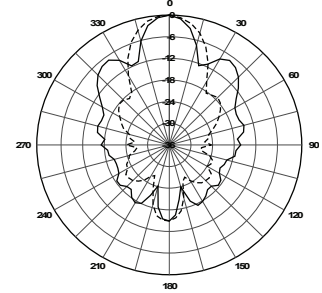

2,000 Hz

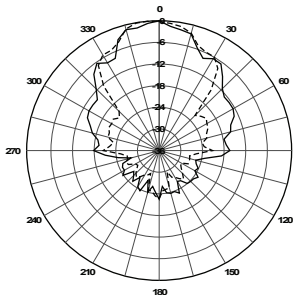

4,000 Hz

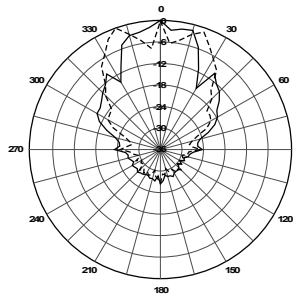

8,000 Hz

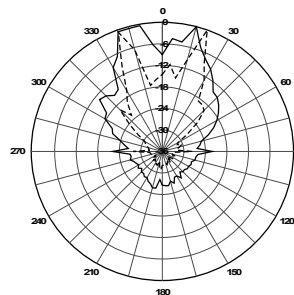

10,000 Hz

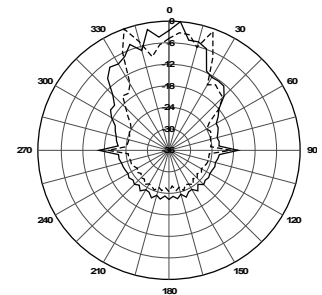

Technical data, EASE™ plots, SoundTubeSPEC™ software and product downloads available at www.soundtube.com

Mechanical Drawings

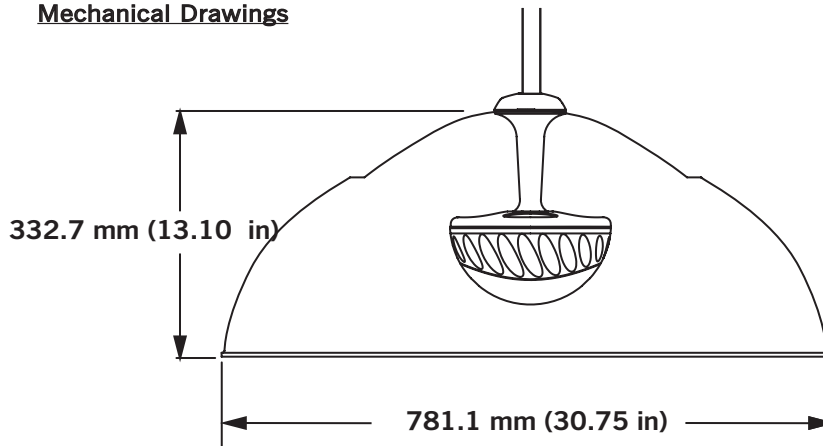

Included Accessories

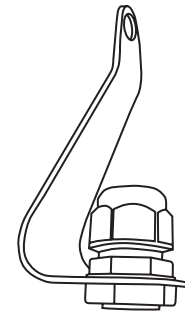

Cable hanging
bracket and mount-
ing bushing

Optional Accessories



AC-CFP Custom Printed SoundSleeve™

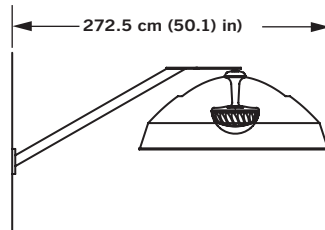

AC-WB4 Wall Mount Bracket

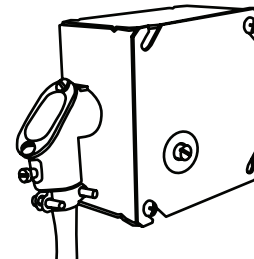

AC-JB10-XFMR & AC-JB20-XFMR
10- and 20-watt transformers in
junction box

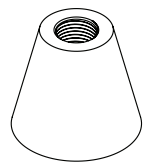

AC-RMA Rigid
Mount Adaptor

SoundTube Entertainment manufactures a complete line of speakers for:
Open-Ceiling • In-Ceiling • Surface-Mount • Outdoor • Sound-Focusing

All SoundTube products are designed and engineered in the USA.