



## Preliminary Data: SM82-EZ

## Mounting hardware included

System Type	8 inch offset, surface-mount, ported (64-watt transformer for 25/70.7/100-volt or 8 ohm direct)
Impedance (nominal) <sup>1</sup>	8 ohms
Sensitivity dB @ 2.83 V/1 m	90.0 dB
Sensitivity dB @ 1 W/1 m <sup>2</sup>	90.0 dB
Frequency Response ( - 3 dB) <sup>3</sup>	90 Hz - 22 kHz
Frequency Response ( - 10 dB) <sup>3</sup>	65 Hz - 22 kHz
Max. Program Power <sup>4</sup>	128 W
Max. Continuous Power RMS <sup>5</sup>	64 W
Max. Power SPL @ 1 m <sup>6</sup>	109.0 dB
Coverage Angle (-6 dB @ 2 kHz)	100°
Coverage Angle (-6 dB @ 10 kHz)	100°
Coverage Angle (averaged 2-10 kHz)	100°
Directivity Factor (Q)	5.0 (averaged 100 Hz - 10 kHz); 8.0 (2 kHz)
Directivity Index (DI)	5.0 dB (averaged 100 Hz - 10 kHz); 8.0 dB (2 kHz)
Tap Selector	Six-position rotary switch with 8-ohm direct
Transducer - Low-Frequency Driver	203 mm (8.0 in) polypropylene woofer with butyl rubber surround
Transducer - High-Frequency Driver	25 mm (1.0 in) aluminum dome tweeter with waveguide
Low-Frequency Voice Coil	25.4 mm (1.0 in)
Crossover Frequency	2.5 kHz
Network Type - Low Pass	12 dB per octave, 2nd order
Network Type - High Pass	12 dB per octave, 2nd order
Enclosure Material	Injection-molded ABS
Grille	Powder-coated steel
Inputs	Four-pin, 5 mm Euroblock for individual or daisy chain connection
Colors	Black or white
Height	477.0 mm (18.78 in)
Width	13.2 mm (29.00 in)
SM Depth (including bracket)	390.4 mm (15.37 in)
Weight	13.2 kg (29.0 lbs.)
Shipping Weight	15.5 kg (34.0 lbs.)
Included Accessories	Surface-mount bracket, seismic safety cable, Euroblock connector, terminal weather boot and paint mask
Packaging	One per box
Regulatory - CE	Approved
Regulatory - UL	UL 1480 pending
<b>Transformer Taps</b>	

- 1 Impedance listed per IEC 60268-5 with a minimum less than 80% the nominal impedance
- 2 1 W 1 m sensitivity determined using nominal impedance
- 3 Frequency response measured in half or full space as dictated by speaker mounting configuration
- 4 Max program power is 3 dB above max continuous power
- 5 Continuous power rating, EIA-426-B test
- 6 Max output based on max continuous power

70.7 V	Output	100 V	Output	25 V	Output
64 W	108.0 dB	64 W	108.0 dB	8 W	99.0 dB
32 W	105.0 dB	32 W	105.0 dB	4 W	96.0 dB
16 W	102.0 dB	16 W	102.0 dB	2 W	93.0 dB
8 W	99.0 dB	8 W	99.0 dB	1 W	90.0 dB
4 W	96.0 dB				

## Key Features

- The SM82-EZ is a cost-conscious, durable, surface-mount loudspeaker with proprietary rapid installation technology.
- One 203 mm (8.0 in) polypropylene woofer and one offset 25 mm (1.0 in) aluminum dome tweeter with waveguide.
- Extended full-frequency response down to 65 Hz, - 10 dB.
- 64-watt low-insertion loss transformer with maximum output (109 dB max. SPL, 90 dB sensitivity).
- Easy-access six-position selectable tap switch for 25-, 70.7- and 100-volt applications with voice coil direct position.
- Powder-coated steel grille with tool-free locking system.
- Easy to install, proprietary, low-profile Stealth™ bracket with a direct-drive cam-wedge for stable, precise, tool-free aiming to 90° in any direction.
- Pre-mountable pole- and surface-mount bracket allows for quick and easy division of labor.
- Tool-free one-way locking knob ensures ease of installation and theft resistance.
- Included accessories: Surface-mount bracket, seismic safety cable, paint mask, Euroblock connector and terminal weather boot.
- High-quality black or white paint finish, custom colors optional.

## Description

The SM82-EZ is a cost-effective, high-efficiency surface-mount loudspeaker for distributed or 8 ohm applications. The SM82-EZ incorporates a dedicated 8 inch polypropylene woofer and an offset 1 inch aluminum dome tweeter with waveguide to deliver superb intelligibility for background to foreground music and messaging (up to 109 dB max. SPL).

The SM82-EZ uses a 64-watt low-insertion loss transformer and a six-position tap switch with a voice coil direct position. Mounting for the SM82-EZ includes a proprietary, tool-free, low-profile Stealth™ bracket with a direct-drive cam-wedge for stable and precise aiming to 90° in one direction. Mounting hardware is constructed of powder-coated steel, and includes a pre-mountable pole or surface bracket for quick and easy division of labor.



## Applications

Engineered for cost-conscious applications requiring true intelligibility, quality low-frequency response and quick installation, the versatile SM82-EZ delivers smooth and even coverage ideal for casinos, convention centers, gyms, nightclubs, aerobic rooms, airports, super stores, arenas, theme parks, transportation hubs, shipping centers and stadiums. For additional low-end response down to 40 Hz (-10 dB) the powered SM1001-P may be incorporated.

## Patented SoundTube Technologies

SoundTube Entertainment and MSE Audio Group constantly develop new technologies that enhance audio product performance. SoundTube Entertainment innovations are protected by multiple U.S. and international patents, which explicitly cover SoundTube dispersion, enclosure and dome technologies. MSE Audio Group actively defends its patents in order to protect SoundTube resellers and end users.

## Technical Data and Specification Tools

### Technical Data

SoundTube Entertainment strives to provide complete and effective technical information and data to dealers, engineers and designers. All data are available from SoundTube Entertainment or at [www.soundtube.com](http://www.soundtube.com).

Technical data and downloads include:

EASE™ data – 3-D polar plots.

EASE™ Address – 2-D modeling for distributed systems

Autodesk® Revit® software

Tech Sheets – Technical information and architectural specs for system engineers

SoundTubeSPEC™ – Proprietary

speaker placement software

## Independent Data Acquisition and Verification

All data for SoundTube speakers are independently collected and verified by NWAALabs ([www.nwaalabs.com](http://www.nwaalabs.com)) using their proprietary MACH testing system. All data are collected and analyzed according to ASTM, ISO and AES standards using EASERA, TEF and MLSSA. Full balloon data including both phase and magnitude are compiled into a variety of formats including EASE 4.x, GLL and CLF.

## Architectural Specifications

The loudspeaker shall consist of one 203 mm (8.0 in) low-frequency transducer and one 25 mm (1.0 in) high-frequency transducer with an integrated 100° x 100° waveguide. The system shall include a crossover network and 64-watt transformer installed in the enclosure. The low-frequency voice coil diameter shall be 25.4 mm (1.0 in).

Performance specifications for a typical production unit shall be as follows: Useable frequency response shall extend from 65 Hz – 22 kHz (-10 dB). Measured sensitivity (2.83 volt, 1 meter) shall be at least 90 dB. The speaker shall have a nominal impedance of 8 ohms. The speaker shall be available for 25-, 70.7- and 100-volt modes and shall include a six-position tap switch with a voice coil direct position.

The frequency-dividing network shall have a crossover frequency of 2.5 kHz with slopes of 12 dB per octave (2nd order) for both low- and high-pass filters. Rated power capacity shall be at least 64 watts continuous (RMS) and conform to EIA-426 testing. Maximum continuous output at 1 meter shall be 109.0 dB.

The low-frequency transducer shall have a polypropylene cone with butyl rubber sur-

round. The high-frequency transducer shall be an aluminum convex dome and shall include a 100° x 100° waveguide.

The grille shall be powder-coated steel with a tool-free locking system. Mounting for the SM82-EZ includes a proprietary, tool-free, low-profile Stealth™ bracket with an integrated internal wedge cam for stable and precise aiming from 0 to 90°. Mounting hardware is constructed of powder-coated steel.

The pre-mountable pole- or surface-mount bracket allows for quick and easy division of labor applications. The mounting hardware includes a proprietary, tool-less, theft-resistant knob and auxiliary seismic restraint cable (a tool is required to loosen the knob).

Overall dimensions including the mounting plate and bracket for the SM82-EZ are 477.0 mm (18.78 in) tall by 295.9 mm (11.65 in) wide by 390.4 mm (15.37 in) deep (including bracket).

The system shall be the SM82-EZ for both low- and high-impedance applications.

## SoundTube Entertainment

6430 North Business Park Loop  
Park City, Utah 84098  
Phone 435.647.9555  
Fax 435.647.9666  
Toll Free 800.647.TUBE  
[www.soundtube.com](http://www.soundtube.com)

**All SoundTube products come with a 5-year limited warranty.**



**Graphs and Plots**

**Frequency Response**

N/A

**Impedance/Phase**

N/A

---

**Vertical Beamwidth**

N/A

**Directivity Index (DI)**

N/A



Polar Plots

———— Horizontal  
 - - - - - Vertical

125 Hz	250 Hz	500 Hz	1,000 Hz
N/A	N/A	N/A	N/A
2,000 Hz	4,000 Hz	8,000 Hz	10,000 Hz
N/A	N/A	N/A	N/A

Mechanical Drawings

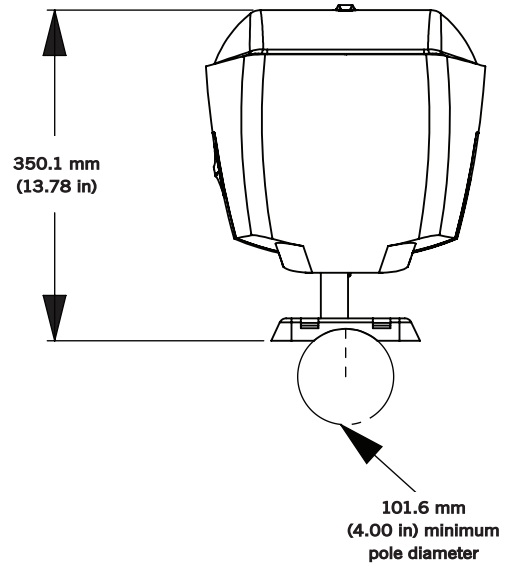
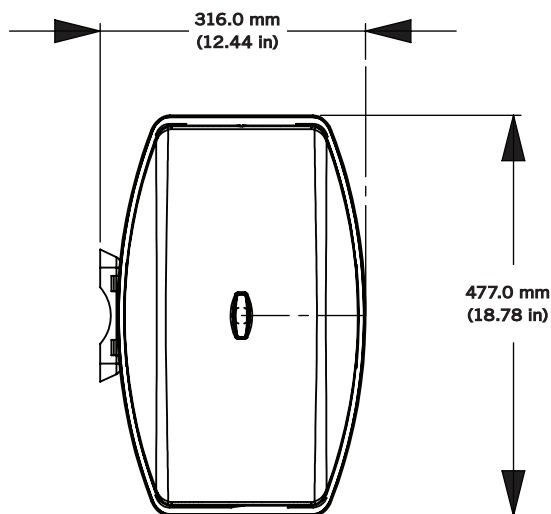

SoundTube Entertainment manufactures a complete line of speakers for:  
**Open-Ceiling • In-Ceiling • Surface-Mount • Outdoor • Sound-Focusing**

All SoundTube products are designed and engineered in the USA.