



Specifications: HP129a

System Type	12-inch, two-way, high-power, ported (150-watt transformer for 70.0/100/25-volt or transformer bypass position)
Impedance (nominal) ¹	8 ohms
Sensitivity dB @ 2.83 V/1 m	97.0 dB
Sensitivity dB @ 1 W/1 m ²	97.0 dB
Frequency Response (-3 dB) ³	118 Hz - 16 kHz
Frequency Response (-10 dB) ³	73 Hz - 19 kHz
Max. Program Power ⁴	300 W
Max. Continuous Power RMS ⁵	150 W
Max. Power SPL @ 1 m ⁶	119.0 dB
Coverage Angle (-6 dB @ 2 kHz)	80°
Coverage Angle (-6 dB @ 10 kHz)	90°
Coverage Angle (Avg. 2 - 10 kHz)	95°
Directivity Factor (Q)	6.1 (Avg. 100 Hz - 10 kHz) 10 (2 kHz)
Directivity Index (DI)	6.6 dB (Avg. 100 Hz - 10 kHz) ; 10 dB (2 kHz)
Tap Selector	Five-position rotary switch with transformer bypass position
Transducer - Low-Frequency Driver	305 mm (12 in.) treated fiber cone, treated cloth surround
Transducer - High-Frequency Driver	1 x 35 mm (1.375 in.) Mylar compression driver with waveguide
Low Frequency Voice Coil	50.8 mm (2.00 in.)
Crossover Frequency	2.2 kHz
Network Type: Low-Pass	24 dB per octave, 4th order
Network Type: High-Pass	24 dB per octave, 4th order
Enclosure Material	Injection molded ABS baffle, glass fiber reinforced
Grille	Iridite-plated steel with powder-coat finish
Inputs	Four-pin, 5.08 mm Euroblock for individual or daisy chain connection
Colors	Black or white
Height	452.1 mm (17.8 in.)
Diameter	457.2 mm (18.0 in.)
Weight	16.4 kg (36.0 lb)
Shipping Weight	18.9 kg (41.5 lb)
Included accessories	Hanging hardware, Euroblock connector and terminal weather boot
Optional accessories	Surface mount bracket (AC-HP-SM129)
Packaging	One per box
Regulatory - UL	UL 1480 (UEAY) approved
RoHS	Approved

Transformer Taps

	70.7 V	Output	100 V	Output	20 V	Output
¹ Impedance listed per IEC 60268-5						
² 1 W 1 m sensitivity determined using nominal impedance	150 W	119.0 dB	150 W	119.0 dB	19 W	110.0 dB
³ Frequency response measured in half or full space as dictated by speaker mounting configuration	75 W	116.0 dB	75 W	116.0 dB	9.5 W	107.0 dB
⁴ Max program power is 3 dB above max continuous power	38 W	113.0 dB	38 W	113.0 dB	4.8 W	104.0 dB
⁵ Continuous power rating, EIA-426-B test	19 W	110.0 dB			2.4 W	101.0 dB

⁶ Max output based on max continuous power
⁷ Max useable SPL based on testing by NWA Labs

Key Features

- Patented BroadBeamHP® coverage pattern providing smooth response and maximum SPL across the audio spectrum.
- One 12 inch (305 mm) treated fiber cone with a treated cloth surround and one 1.375 inch (35 mm) Mylar compression driver with waveguide.
- Weatherized components for indoor/outdoor applications and a ported enclosure for added bass response (down to 73 Hz, -10 dB).
- High-SPL, high-efficiency system for the sound reinforcement and PA markets.
- Easy-access, five-position tap switch for 25/70.7/100-volt applications with transformer bypass position.
- Reduced amplification costs and maximum efficiency (97 dB sensitivity), with 8-ohm impedance.
- UL 1480 (UEAY) approved.
- High quality black or white painted finish. Custom colors available.
- Included accessories: hanging hardware, Euroblock connector, terminal weather boot.
- Optional accessory: surface-mount bracket (AC-HP-SM129).

Description

The HP129a is a 12-inch, coaxial, hanging speaker with a surface-mount option and a proprietary BroadBeamHP® waveguide. Engineered to deliver true high-SPL performance, the HP129a incorporates a 12-inch treated fiber cone and one 35 mm (1.38 in.) Mylar compression driver with a professional-grade electro-acoustic sub-assembly. The result is a pendant-mount speaker with maximum efficiency (97 dB 1W/1M) and an extended frequency response from 73 Hz – 19 kHz (-10 dB). For lasting performance, the enclosure is made from injection-molded, glass-filled ABS.

Mounting hardware is included and features hanging and safety cables, Euroblock connector and terminal weather boot. For easy ordering, stocking and installation, every speaker is equipped with a five-position tap switch for 25-, 70.7- and 100-volt applications with a transformer bypass setting. For surface-mount applications, SoundTube offers a surface mount adaptor (AC-HP-SM129).



Applications

Developed specifically for true PA and sound reinforcement applications including arenas, stadiums, gyms, ice rinks, nightclubs and other open ceiling or outdoor applications where rapid installation, high-SPL and lasting durability are required.

BroadBeam[®] Wide Dispersion Technology

SoundTube's proprietary BroadBeam[®] technology incorporates a high-frequency waveguide mated to a 1-inch convex aluminum tweeter. BroadBeam[®] waveguide technology delivers a consistent BroadBeam[®] dispersion pattern across the upper registers of the frequency spectrum. The result is an audio system requiring fewer speakers with higher intelligibility, offering reduced power needs, shorter installation time and cost savings on shipping and labor.

Patented SoundTube Technologies

SoundTube Entertainment and the MSE Audio Group constantly develop new technologies which enhance audio product performance. SoundTube Entertainment innovations are protected by multiple U.S. and international patents, which explicitly cover SoundTube dome, enclosure and dispersion technologies. The MSE Audio Group actively defends its patents in order to protect SoundTube resellers and end-users

Technical Data and Specification Tools

Technical Data

SoundTube Entertainment strives to provide complete and effective technical information and data to dealers, engineers and designers. All data are available from SoundTube Entertainment or at www.soundtube.com and includes EASE[™] Data – 3-D polar plots and SoundTubeSPEC[™] – proprietary SoundTube speaker placement software.

Acquisition & Verification

All data for SoundTube speakers is independently collected from and verified by NWAALabs (www.nwaalabs.com)

using their proprietary MACH testing system. All data are collected and analyzed according to ASTM, ISO and AES standards using EASERA, TEF and MLSSA. Full balloon data including both phase and magnitude is compiled into a variety of formats including EASE 4.x, GLL and CLF.

Architectural Specifications

The loudspeaker shall consist of one 305 mm (12 in.) low-frequency transducer and one 35 mm (1.375 in.) high-frequency transducer with a frequency dividing network installed in a ported enclosure. The low-frequency voice coil diameter shall be 50.8 mm (2.0 in.).

Performance specifications of a typical production unit shall be as follows: Usable frequency range shall extend from 73 Hz - 19 kHz, -10 dB. The loudspeaker shall be available with selectable 25/70.7/100-volt tap switch with transformer bypass position. The frequency dividing network shall have a crossover frequency of 2.2 kHz. Rated power capacity of the components and network shall be at least 150-watts continuous RMS and conform to EIA-426-B testing. Maximum continuous output at 1 meter shall be at least 119 dB.

The low-frequency transducer shall have treated fiber cone material with a treated cloth surround. The high-frequency transducer shall be constructed of Mylar material.

Installation for the speaker shall be by galvanized steel cable affixed to the speaker chassis via an integrated snap hook. For safety redundancy, a secondary steel cable shall be included. The external wiring input connector shall be a four-pin, 5.08 mm Euroblock for 8 ohm or distributed systems and shall accept 10-22-gauge wire. The unit shall be for indoor and outdoor applications and have a weather-resistant boot covering all wire connections. The system shall ship complete with mounting hardware including hanging and safety cables, Euroblock connector and terminal weather boot. The speaker has an optional surface mount bracket (AC-HP-SM129).

The ported enclosure shall be constructed from injection molded, glass-

reinforced ABS with a total volume of 1700 cubic inches. The grille shall be constructed of iridite-plated steel with a powder coat finish and affix to the speaker via friction fit with two blind mounted, radial screws.

The unit is factory preset to the 150-watt setting in the 70.7-volt operating mode, with a tap switch located on the front baffle of the speaker and is accessible by a removable grille plug. Signal input shall be by four-pin Euro-block connector.

The system shall be the SoundTube HP129a for both low- and high-impedance applications.

SoundTube Entertainment

6430 North Business Park Loop
Park City, Utah 84098
Phone 435.647.9555
Fax 435.647.9666
Toll Free 800.647.TUBE
www.soundtube.com

All SoundTube products come with a 5-year limited warranty.

Graphs and Plots

Frequency Response

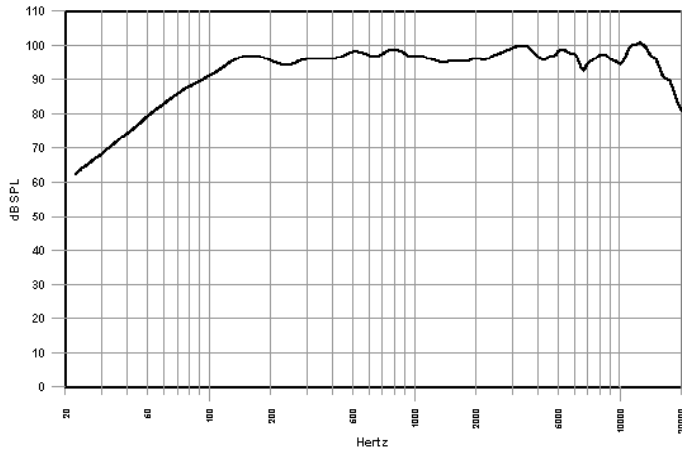

Phase/Impedance Response

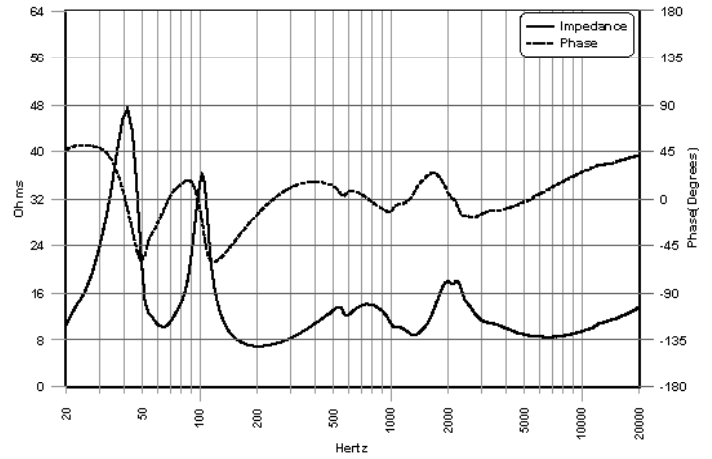

Vertical Beamwidth

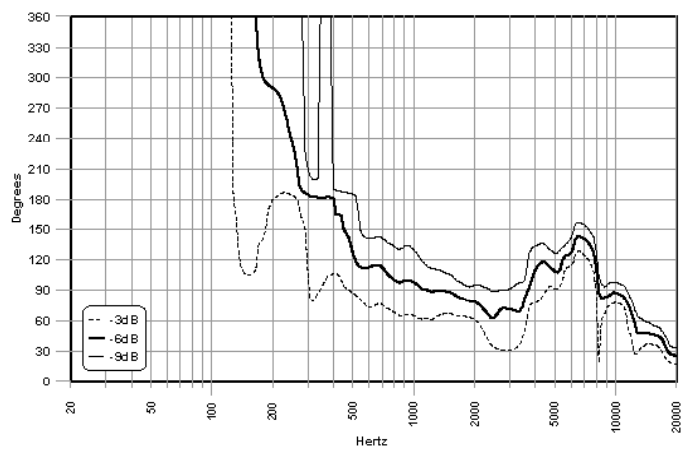

Directivity Index (DI)

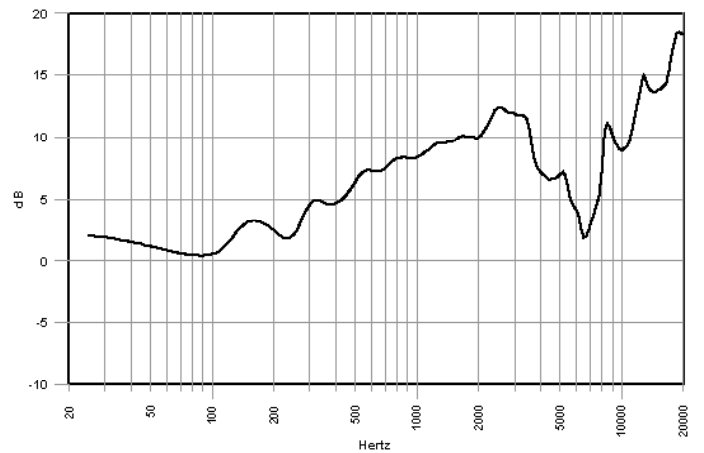

Polar Plots

— Horizontal
- - - Vertical

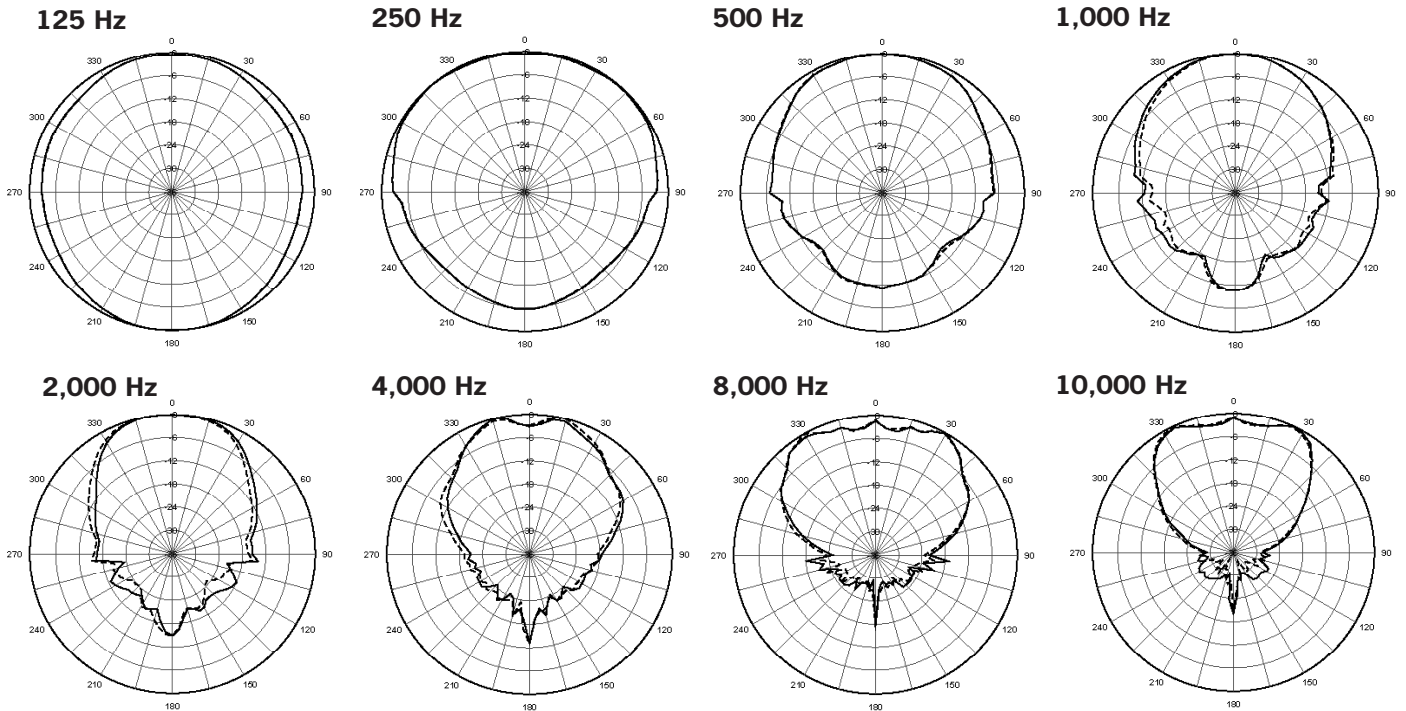

Technical data, EASE™ plots, SoundTubeSPEC™ software and product downloads available at www.soundtube.com

Mechanical Drawings

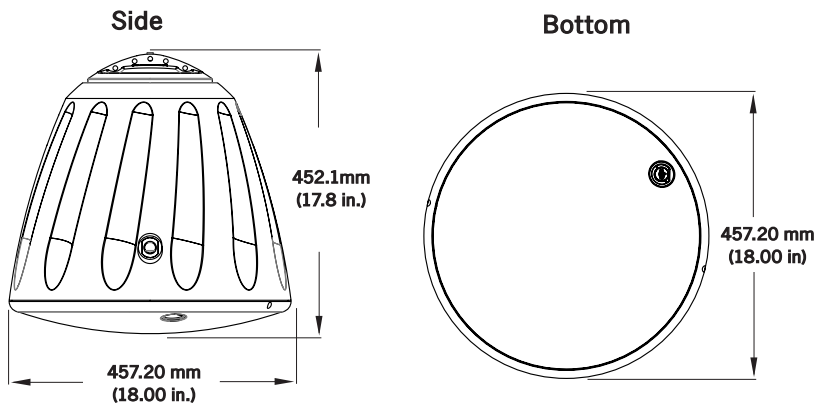

Optional Accessories

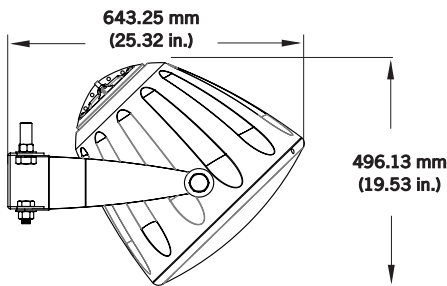

Surface Mount Bracket (AC-HP-SM129)

Included Accessories

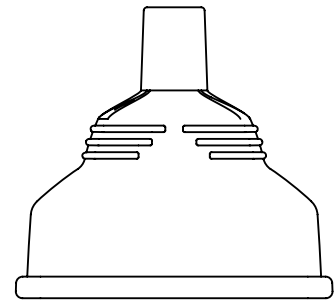

Terminal Weather Boot

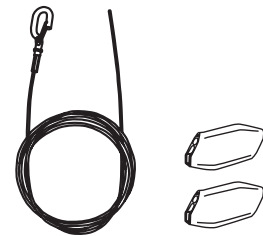

Hanging Hardware

SoundTube Entertainment manufactures a complete line of speakers for:
Open-Ceiling • In-Ceiling • Surface-Mount • Outdoor • Sound-Focusing

All SoundTube products are designed and engineered in the USA.